

### Explosive view for SC15000TE-ATS

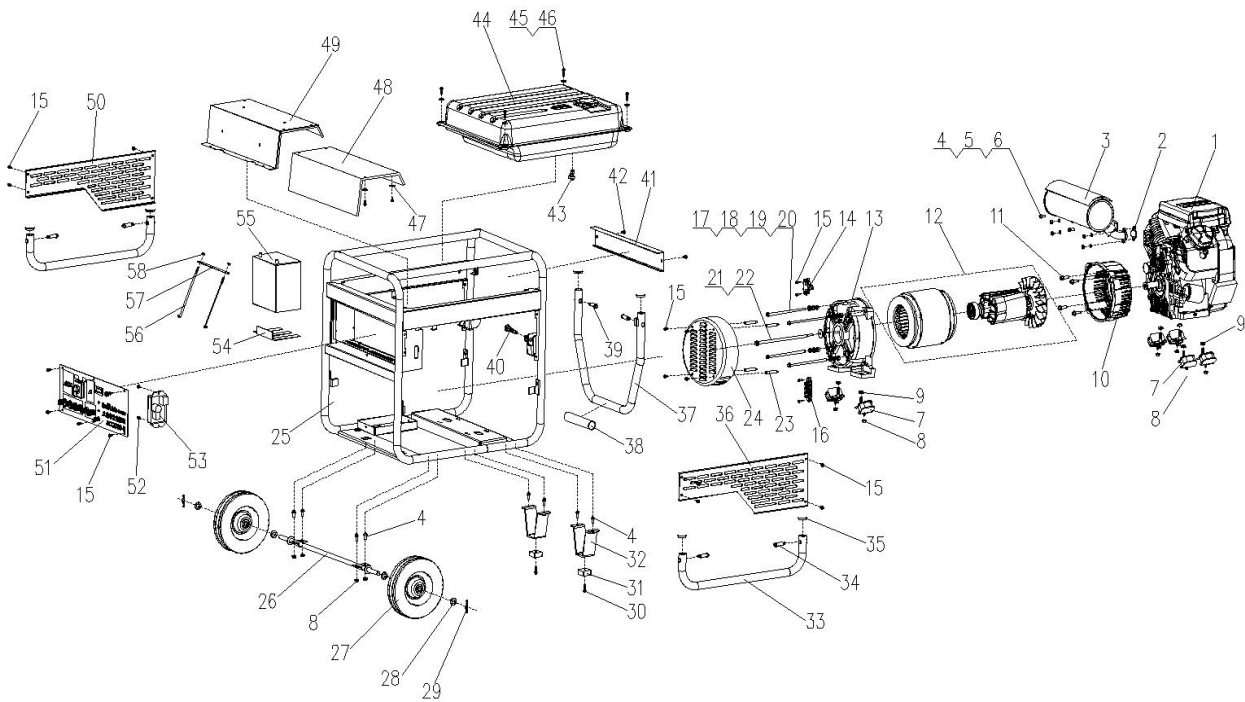

NO.	Part Name	Description	QTY
1	Engine	GB750/50HZ/3:16/14KW (3000RPM) / V / CE	1
2	Muffler gasket	ZS2V78	2
3	Muffler	10KW/142, 156/B4/LC2V78/Φ47*1.2	1
4	Flange Bolt	M8*1.25/20/S=10/8.8	10
5	Hexagon nut	M8*P1.25/S=13/m=6.8	4
6	Spring washer	Φ8.5	4
7	Shock pad	10KW/65mm, M8*1.25*18/M10*1.25*43/SA	6
8	Flange Nut	M8	6
9	Flange Nut	M10×P1.25	4
10	alternator cover	Φ270/10KW/146	1
11	Flange Bolt	M10×30×P1.25	4

12	alternator component	12KW/220V380V/50HZ/ACY/270*140A/ROHS/270/0.5/3:16/AL/	1
13	alternator supporter	Φ 270/165/2-Φ 12*44/214±44	1
14	carbon brush	270X140	1
15	Flange Bolt	M6*1/12/S=10/8.8	32
16	wiring terminal	270X140	1
17	Hexagon flange bolt	M10*1.25/200/S=14/8.8	4
18	flat washer	Φ 10.5*Φ 20*2	4
19	Spring washer	Φ 10.5/GB93	4
20	Hexagon nut	M10*1.25/S=16/8.8/GB/T 6171	4
21	Flange Bolt	M10*1.25/270/S=13/9.8	1
22	flat washer	Φ 10*Φ 30*2.5	1
23	support pillar	M6*12/ Φ 10*58/M6*15/45	4
24	End cover, Alternator	Φ275*79/4-Φ7.5	1
25	Frame assembly	12KW/Φ32/770*600*800/B4/GB750	1
26	axle	Φ16*770/2-Φ3/74/4-M8*492*45	1
27	Wheel	10"/ Φ 16*68	2
28	flat washer	Φ10.5*Φ20*2	4
29	Locating pin lock clip	Φ2*18	2
30	Flange Bolt	M6*1/20/S=8/8.8	2
31	Vibration damping pad	40*40*20	2
32	Supporter Components	U/140*66.8*122/2-M8*114/3/B4/Q235/10KW	2
33	Handle assembly	Φ32*2/694*161/B4	2
34	Handle pin	M10*Φ18*60/250~280HB	4
35	Choke plug	Φ32*Φ26.6*11.5	6
36	Guard Plate	702*220*117/B4/2MM/	1
37	Handle assembly	Φ32*2/U/490*426/B4/Φ17*Φ13.7*33	1
38	Handle gum cover	Φ 31*Φ 39*200	1
39	handle components		1

39-1	Pin	AB80、319454	1
39-2	spring fastener	Φ10.5*Φ13.5*28/6/319452	1
39-3	handle components	Φ28*Φ6.5*20/PE/312016	1
39-4	Spring pad	Φ5	1
39-5	Flange Bolt	M5*0.8/16/S=8/8.8	1
40	housing separator	2KW/507/538*80*15/B4/2	1
40	Handle pin	M10*Φ13.5*63/G7D6T80/250~280HB	2
41	Fuel tank switch	0 φ 12*2	1
42	fuel tank	LD-045-D/10KW/4- Φ 11*630*498/45L/RE/O	1
43	Flange Bolt	M6*1/25/S=10/8.8	4
44	Oil Tank gasket	Φ 6* Φ 22*2	4
45	flat washer	Φ 6.5* Φ 18*1.6	10
46	Nylon nut	M6*P1/S=10	6
47	Oil tank heat shield	10KW/2-Φ9*416/6-Φ8*320/1.5/B4	1
48	Heat Insulation Sponge	540*400/12KW	1
49	Guard Plate	662*220/ST12	1
50	Control Panel Assembly	12KW/230V400V/250V16A/230V-400V16A/1P- 16A(1.15)/3P-16A(1.25)/3P-22A(1.15)	1
51	Flange Bolt	M6*1/16/S=8/8.8	2
52	AVR	270/10KW/AVR/ROHS/TT93-7	1
53	Rubber	130*30*2.5	3
54	Battery	12V.36Ah/UL/CE/6-QW-36	1
55	Battery Mounting Bolt	6*215/CPG6600E	2
56	Battery Holder	240*16/2-Φ6/212/B4/L	1
57	Flange Nut	M6*1.0/S=10/8.8	2